

PACKING LIST

- 1 - Problast 3 ESD
- 1 - Instructions
- 1 - DC Power Supply

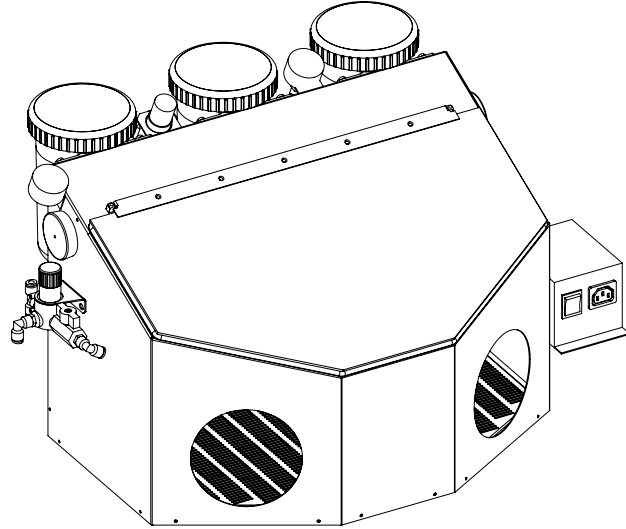

INSTALLATION & OPERATION

1. Remove all packing material.
2. Attach the ESD regulator to bracket (on left side of unit) with nut included on regulator.
3. The ESD generator must be connected to the supply cord and green ground wire. The loose black cord coming from the ESD air delivery unit (on rear of unit) is to be inserted and screwed into the back of the ESD generator. Either one of the two ports will work sufficiently. Attach the end of the green wire that has a "U" shaped connector to the ground bolt in the center of the two output ports on the ESD generator with supplied lock nut already on bolt.
4. Unscrew lids on abrasive storage tanks.
5. Fill media storage tanks to fill line with blasting media in the micron size specified on tank label. **DO NOT OVERFILL** - clogging may result.
6. Inspect lid for any cracks or areas that might create leaks. Wipe off excess abrasive and screw lid securely back into place. Do not overtighten.

Part No.	Nozzle Size, Inches (mm)	Color	Recommended Media
Long Lasting Crystal Tips (2 per package)			
97902	Medium, .032" (.8mm)	Blue	25/50 μm Al_2O_3
97903	Large, .048" (1.2mm)	Black	50/100 μm Al_2O_3 , 50 μm Glass
97904	Extra Large, .065" (1.6mm)	Red	100-250 μm Al_2O_3 , 50/100 μm Glass
Precision Tungsten Carbide Tips (1 per package)			
97905	Small, .026" (.65mm)	Yellow	25 μm Al_2O_3
97906	Medium, .036"(.91mm)	Green	50/100 μm Al_2O_3 , 50 μm Glass
97907	Large, .059" (1.5mm)	Violet	100-250 μm Al_2O_3 , 50/100 μm Glass

- Attach your 1/4" ID (outside diameter) hose air supply line to the quick connect on the back of the unit. If you do not have the proper hose for the quick disconnect on the unit, a barb fitting is provided. To use the barb fitting, remove the quick disconnect fitting with a wrench and replace with the barb fitting. NEVER depressurize the system by disconnecting the air supply line while under pressure. Abrasive will be forced into the foot valve and regulator, causing damage.

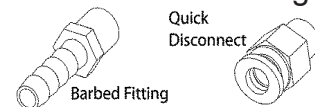

For more help visit: [www.vaniman.com/air-supply-connections-blasters/](http://www.vaniman.com/air-supply-connections-blasters/**)

- Inside the Problast is the "TANK" selector knob for using each of the tanks. For ease of use the handpieces, tanks, and valves are all color-coded. Select the tank of choice making sure this knob is dialed all the way to the appropriate position. The downward position will shut off air pressure to the tanks. (This "off" position should be used when filling the abrasive storage tanks.)
- Regulate air pressure by turning the air regulator knob. Unlock by pulling up the knob then turn. Pressure reading will indicate pressure. DO NOT adjust above 100 psi (7 BARS).
- To engage the ESD air flow, turn the valve on the rear of the unit for the ESD air supply. Any time full ESD protection is required, this valve must be on. The gauge should read roughly 30 psi before depressing foot pedal and can be changed by removing the tamper-resistant knob. This can be adjusted to increase flow by removing the snap-ring on the regulator knob, adjusting, and replacing the snap ring.
- Turn the red power switch on the ESD power supply on, it will light when connected correctly. Both the power supply and the blaster's light cord must be connected to a properly grounded wall plug or cable.
- To begin blasting, use the foot pedal to start the flow of air and blasting media. Release the foot pedal to stop the flow.

***** A dust collector is strongly recommended to contain the dust inside the cabinet.*****

Abrasive-Vac Dust Collector P/N 10660

REPLACEMENT PARTS

Blasting Media

Part No.	Material	Size	Applications
97921	Aluminum Oxide	25µm	Fine surfacing of metal or hard materials.
97922	Aluminum Oxide	50µm	Deburring and deflashing of metals and other hard materials.
97923	Aluminum Oxide	100µm	Aggressive removal of materials, semi-rough finished surface.
97924	Aluminum Oxide	250µm	Bulk removal or surface cleaning of tough materials. Rough surface preparation.
97925	Glass Bead	50µm	Smoothing/polishing. Cleans and polishes without removing material.

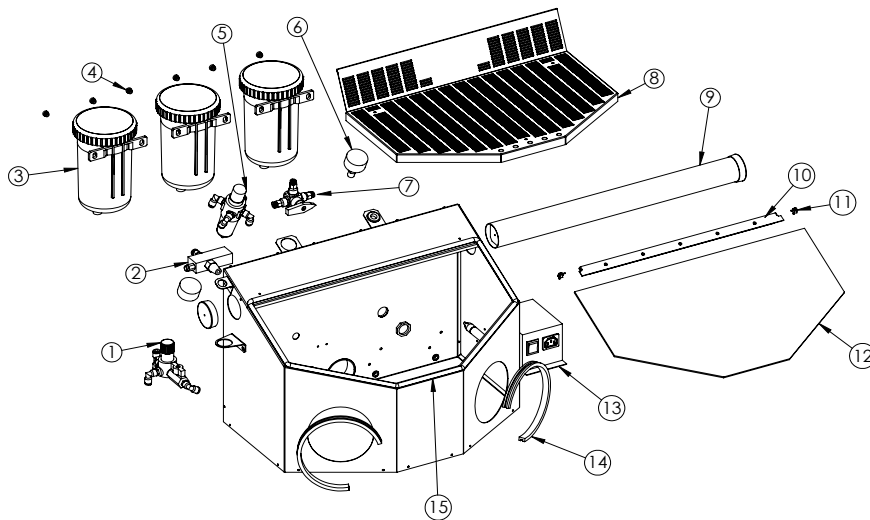

<i>Fig. #</i>	<i>Description</i>	<i>Reorder Part Number</i>
1	ESD Regulator	2227
2	ESD Air Delivery Unit	2216
3	Sand Jar Assembly 25 micron Sand Jar Assembly 50-100 micron Sand Jar Assembly 110-250 micron	97956 97957 97958
4	Thumb Nut	2266
5	Regulator	2293
6	Air Pressure Gauge	2112
7	Selector Valve Assembly	2294
8	Floor Screen	2240
9	LED Light Assembly	97969
10	Window Bracket Assembly (with glass)	2282
11	Pin-Hinge Assembly	2290
12	Window Only	2241
13	ESD Generator	2216
14	Cuff Holder	2260
Not Shown	Cuff (black cloth)	2033XL
15	Window Gasket Kit	2030B
Not Shown	Blow Off Gun	2285
Not Shown	Window Protector Shield	97951

TUBING & HANDPIECE MAINTENANCE INSTRUCTIONS

1. Remove the tubing from the bottom fitting of the sand tank. See Illustration 2 for instructions on quick fittings.
2. Remove the handpiece assembly from inside the cabinet by pulling the tubing through the rubber grommet.
3. Use Illustration 1 to unscrew the nozzle cap (7) and remove the tip (6) and the sealing washer (5). Using a pair of pliers, grasp the handpiece insert (4) and with a twisting motion pull the tubing through the handle (3). Pull the handpiece insert from the tubing by twisting and pulling.

NOTE: On some units, a steel barbed nozzle may be in the tubing - this should be removed from the tubing and discarded it can no longer be used with the new long lasting polyurethane tubing. It may be necessary to moisten the tubing and/or soak the tubing in warm water to ease onto the barb at the bottom of the sand tank.

4. Using the new piece of tubing, push the tubing through the handle-using a twisting motion. When the tubing is through the handle, pull in out several inches and press the handpiece insert all the way onto the end of the tubing, until the tubing is flush with the front of the insert (see inset). It may be necessary to moisten the tubing to ease the installation of the handpiece insert.
5. Pull the tubing back into the handle until the collar on the handpiece insert is butted-up to the end of the handle. Pull the tubing through the rubber grommet and re-attach it to the jar assembly by pushing it into the quick-release fitting. Re-assemble the sealing washer, tip and nozzle cap to the handle.

Note: ESD Grounding not shown on this diagram

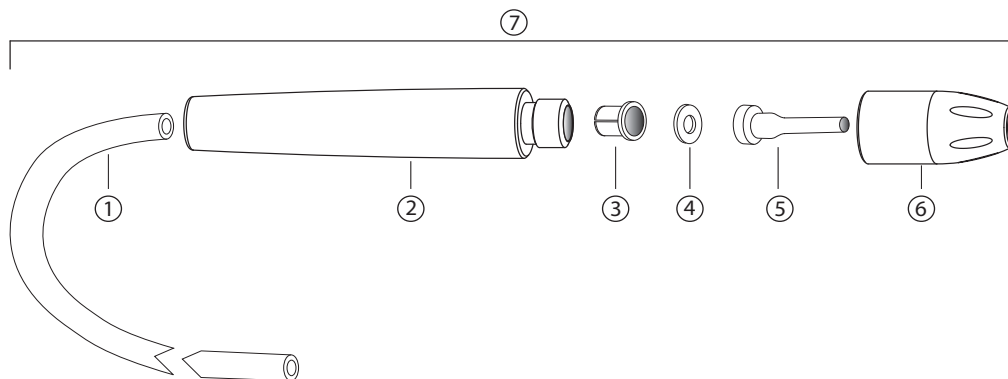
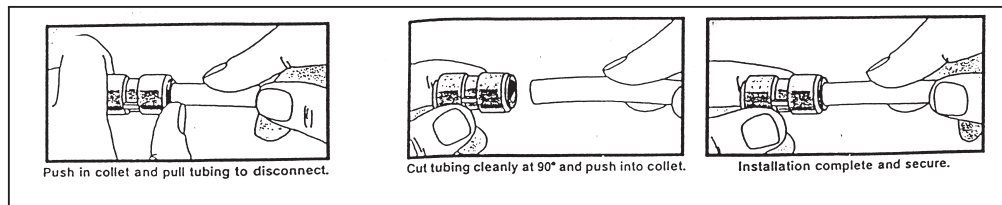

Fig.	Reorder #
1	2192
2	2191
3	2187
4	2188
5	varies, #4 Included
6	2177
7	97959, #4 & #5 Not Included

Illustration 2



PLUMBING

