



PORTABLE AIR COMPRESSOR OWNER'S MANUAL

MODEL: JC10PLUS

SERIAL NUMBER: _____

If after reading this manual you have any questions whatsoever on the proper installation, operation, or maintenance of your air compressor please feel free to contact our Customer Service Department at 1-800-826-4626

We would love to hear from you!



- To order replacement parts:
1. Give compressor model number
 2. Give compressor serial number
 3. Name of part
 4. Part number
 5. Quantity required

RECORD OF PERTINENT INFORMATION

Make a permanent record of the model and serial number of your new air compressor here. You'll save time and expense by including this reference information when requesting service or replacement parts.

Place & Date of Purchase		Volts
Model		HZ
Serial #		HP

With the tank gauge at 0 PSI and air line(s) disconnected, close drain valve(s) and record the amount of time it takes to build tank pressure on the space provided. Periodically test your air compressor against this pump-up time to determine if it is operating correctly.

From 0 to 125 *PSI		
Date	Min	Sec
Factory Spec.	0	55

From 0 to _____ *PSI		
Date	Min	Sec

*Factory top pressure settings vary. Write down the top pressure setting of your machine after performing the initial pump-up time test.

TABLE OF CONTENTS

Introduction and Definitions of Safety Warnings	3
Safety Warnings	4-8
JC10PLUS Overview	8
Identification of System Controls	9-10
Pre-Start Checklist	10
Specifications	11
Operation	12-13
Maintenance	13-14
Troubleshooting	15

INTRODUCTION

This manual was compiled for the benefit of the operator. Do not use or allow anyone else to use your air compressor until this manual is read and all safety/operating instructions are understood. By reading and following the instructions contained in this manual, you can achieve years of trouble free service from your new air compressor. If you have any additional safety or operating questions after reading this manual, please contact your distributor or our customer service department. Do not remove or paint over any of the warning decals attached to the compressor.

Definitions – Safety Warnings

Safety symbols are used throughout this manual to alert you to imminently hazardous and potentially hazardous situations. The following definitions describe the level of severity for each signal word.



DANGER: Indicates an imminently hazardous situation which, if not avoided, WILL result in death or serious injury.



WARNING: Indicates a potentially hazardous situation which, if not avoided, COULD result in death or serious injury.



CAUTION: Indicates a potentially hazardous situation which, if not avoided, MAY result in minor or moderate injury or damage to the air compressor, or other property.

⚠️WARNING: Do not start, operate, or service this machine until you read and fully understand owner’s manual. Failure to do so could result in death or serious injury. |

⚠️WARNING: CONTAINS LEAD. May be harmful if eaten or chewed. May generate dust containing lead. Wash hands after use. Keep out of reach of children.

⚠️WARNING: This product can expose you to chemicals including lead, which is known to the State of California to cause cancer and birth defects or other reproductive harm. For more information go to www.P65Warnings.ca.gov.

SAVE THESE INSTRUCTIONS!



⚠️DANGER: RISK OF EXPLOSION OR FIRE

WHAT CAN HAPPEN

HOW TO AVOID IT

<ul style="list-style-type: none"> Electrical components within the motor and pressure switch will spark. This is normal. If electrical sparks from the compressor come into contact with flammable vapors, they may ignite, causing fire or explosion. 	<ul style="list-style-type: none"> Always operate the compressor in a well-ventilated area away from any flammable vapors, liquid, paint, gasoline, or any other combustible material. Always locate compressor at least 20 ft. (6.1m) away from work area if spraying flammable materials. Store flammable materials in a secure location away from the compressor.
<ul style="list-style-type: none"> Inadequate ventilation, or restrictions to any of the compressor’s ventilation openings, will cause serious overheating and could cause a fire. 	<ul style="list-style-type: none"> Never place objects against or on top of an air compressor. Always operate air compressor at least 18” away from any wall or obstruction. Always operate in a clean, dry, and well-ventilated area.
<ul style="list-style-type: none"> Unattended compressors with leaks in the unit or air system could start unexpectedly and repeatedly and could result in overheating, fire, and personal injury or property damage. A fire can occur if spilled gas or vapors come into contact with hot engine parts, lit cigarettes, or other sources of ignition. 	<ul style="list-style-type: none"> Always remain in attendance with the compressor when it is operating. Always turn off and unplug the compressor when it is not in use. Never attempt to fill the gas tank while the engine is hot or running. Add fuel outdoors and in a well-ventilated area. Do not fill gas tank near lit cigarettes or near other sources of ignition.



⚠️DANGER: RISK TO BREATHING (ASPHYXIATION)

WHAT CAN HAPPEN

HOW TO AVOID IT

<ul style="list-style-type: none"> Air from your compressor is not safe for breathing and may contain carbon monoxide, toxic vapors, or solid particles. Serious injury or death may occur from inhaling the compressed air from your air compressor. 	<ul style="list-style-type: none"> Never inhale compressed air directly from the pump, tank, receiver, or breathing device connected to the air compressor. The compressor is not equipped with suitable filters and in-line safety equipment for human consumption. Do not use discharge air for breathing.
<ul style="list-style-type: none"> Sprayed materials such as paint, stucco, insecticides, solvents, etc. may contain harmful vapors and poisons. 	<ul style="list-style-type: none"> Operate compressor and perform work only in a well-ventilated area. Read and follow the safety instructions provided on the label or safety data sheets for the materials you are spraying. Always use certified safety equipment designed for your specific application.
<ul style="list-style-type: none"> For gas-powered compressors, engine exhaust fumes contain poisonous carbon monoxide which is odorless and colorless. Inhaling those fumes could lead to serious injury or death. 	<ul style="list-style-type: none"> Operate compressors only in well-ventilated areas. Avoid inhaling engine exhaust fumes, and never run a small gas-powered engine in a closed building or confined area without adequate ventilation.



⚠️ WARNING: RISK OF BURSTING

AIR TANK: Air tanks do not have an infinite life and should be inspected once every year to ensure they are still safe for use. To find your state pressure vessels inspector, look under the Division of Labor and Industries in the government section of a phone book.

The following conditions could lead to a weakening of the air tank, and result in a violent air tank explosion:

WHAT CAN HAPPEN

HOW TO AVOID IT

- Failure to properly and regularly drain condensed water from the air tanks will lead to rust and thinning of the steel air tank can lead to a violent air tank explosion.
- Modifications, alterations, or attempted repairs made to the air tank can lead to a violent air tank explosion.

- Drain tanks daily or after every 4 hours of use. If a tank develops a leak, replace it immediately with a new air tank, or new complete compressor.
- Never drill into, dent, weld, patch, or modify the air tank, or its attachments in any way. If you are in possession of a tank in which it appears any of those conditions exist or were attempted, discontinue use and replace air tank immediately.

- Unauthorized modifications to the safety valve, pressure switch, pilot unloader valve, or any other component which controls air tank pressure can lead to a violent air tank explosion.

- Never attempt to repair a damaged or leaking air tank. Replace with a new tank immediately.
- The air compressor is designed to safely operate and withstand specific factory set pressure. Never make adjustments or parts substitutions to components that control air tank pressure or factory set operating pressures.
- Do not make alterations to the factory operating pressure settings.
- Before starting, and with air tank pressure at zero, pull the ring on the safety valve to make sure it moves freely.
- Never operate without a factory approved safety valve.

Attachments & Accessories:

- Exceeding the pressure rating of air tools, spray guns, accessories, tires, or any other inflatables can cause them to explode or fly apart.

- Do not use air tools or attachments before reading the owner's manual to determine the safe maximum pressure rating.
- Never exceed the manufacturer's maximum allowable pressure ratings.
- Never use the compressor to inflate small low pressure objects such as children's toys, balls, etc.



⚠️ DANGER: RISK OF INJURY OR PROPERTY DAMAGE WHEN TRANSPORTING OR STORING

WHAT CAN HAPPEN

HOW TO AVOID IT

- Oil from the compressor can leak or spill and could result in fire or breathing hazard; serious injury or death can result. Oil leaks will damage carpets, paint, or any other surfaces.

- Always keep compressor level and never lay on its side. When transporting, always place compressor on a protective mat to prevent against damage from leaks. Always remove compressor from vehicle immediately upon arrival at your destination. If an oil leak is found, follow all local safety codes for cleanup of hazardous materials.



⚠ WARNING: RISK OF ELECTRICAL SHOCK

WHAT CAN HAPPEN

HOW TO AVOID IT

- **Electrical Grounding:** Failure to provide adequate grounding to the compressor could result in serious injury or death from electrocution.

- Always make certain that the electrical circuit to which the compressor is connected provides proper electrical grounding, correct voltage, and adequate fuse protection. If you are unsure, or have any questions about proper electrical grounding, correct voltage, or adequate fuse protection please call us.

- Your air compressor is powered by electricity. Like any electrically powered device, if it is not used properly it may cause electric shock.

- Never operate the compressor outdoors when it is raining, snowing, or in wet conditions.
- Never let your electrical cord lay in water.
- Never operate the compressor with a damaged power cord, or with protective covers damaged or removed.
- Never touch plug with wet hands.
- Never pull on electric cord to disconnect from the outlet.

- Serious injury or death can occur if repairs are attempted by unauthorized personnel.

- Any electrical repairs or wiring performed on this compressor should only be performed by authorized service personnel and in accordance with all national and local electrical codes.



⚠ WARNING: RISK FROM FLYING OBJECTS

WHAT CAN HAPPEN

HOW TO AVOID IT

- Serious injury and property damage can occur from loose debris being propelled at high speeds from the compressed air stream.

- Always wear certified safety equipment: ANSI Z87.1 eye protection (CAN/CSA Z94.3) with side shields when using the compressor.
- Never direct the air stream, nozzle, or sprayer towards any part of your body, other people, or animals.
- Always turn off the compressor and drain tank pressure completely before attempting maintenance or attaching air hose or tools.



⚠ WARNING: RISK OF HOT SURFACES

WHAT CAN HAPPEN

HOW TO AVOID IT

- Serious burn injuries can result from touching exposed metal parts such as the engine or motor, pump, or any part of the copper/braided discharge lines and components. These parts will become hot during operation and stay hot for an extended period of time even after the compressor is shut down.

- Never touch any of the exposed metal parts during operation and for an extended period of time after shut down.
- Do not reach around shrouds or attempt any maintenance until the unit has been allowed to completely cool.



⚠ WARNING: RISK FROM MOVING PARTS

WHAT CAN HAPPEN

HOW TO AVOID IT

- Serious injury or death can occur if moving parts such as belts, flywheels, pulleys, or fans come into contact with you or your clothing.
- An electric air compressor can restart at any time when plugged in, and an unexpected startup can result in serious injury, death, or property damage.
- Attempting to operate the compressor with any damaged or missing parts, protective guards, shrouds, or covers will expose you to moving parts and can result in serious injury or death.

- Prior to operation, always make sure all protective guards and covers are in good condition, and never operate the compressor if any guard or cover has been removed or damaged.
- Always keep your hair, jewelry, clothing, and gloves away from moving parts as they can be caught.
- It is common for air vents to cover moving parts, so they should be avoided as well.
- Always unplug the compressor when not in use.
- Always drain air tank pressure completely before attempting any repairs or maintenance.
- Never allow children or adolescents to operate the air compressor.
- Any repairs to the air compressor must only be made by factory authorized personnel.



⚠ WARNING: RISK FROM LIFTING

WHAT CAN HAPPEN

HOW TO AVOID IT

- Serious injury can result from attempting to lift an object that is too heavy.

- Always obtain assistance from others before attempting to lift any object that is too heavy for you.



⚠ WARNING: RISK OF FALLING

WHAT CAN HAPPEN

HOW TO AVOID IT

- A compressor may vibrate and move during the course of normal operation resulting in a fall from a table, workbench, roof, or other platform causing damage to the compressor, property damage, and could result in serious injury or death to anyone nearby.

- Always operate air compressor in a stable and secure position to prevent accidental movement of the unit. Never operate compressor on a roof or other elevated position. Use air hose to reach high locations.



⚠ WARNING: RISK FROM NOISE

WHAT CAN HAPPEN

HOW TO AVOID IT

- Under some conditions and duration of use, noise from this product may contribute to hearing loss.

- Always wear certified safety equipment: ANSI S12.6 (S3.19) hearing protection.



⚠️ WARNING: RISK OF UNSAFE OPERATION

WHAT CAN HAPPEN

- Serious injury or death can occur to you or others if air compressor is used in an unsafe manner.

HOW TO AVOID IT

- Review and understand all instructions in your owner’s manual.
- Know how to stop the air compressor at all times.
- Do not operate until you are thoroughly familiar with all of the controls.
- Do not operate the compressor if you are fatigued, under the influence of alcohol or drugs, or in any other state which might impair judgment.
- Stay alert while operating the compressor and pay close attention to the task at hand.



⚠️ CAUTION: RISK OF DAMAGE TO AIR COMPRESSOR OR PROPERTY

WHAT CAN HAPPEN

- Failure to transport or operate the compressor properly may result in major repair expenses.

HOW TO AVOID IT

- Check oil levels daily and maintain proper oil levels.
- Always operate compressor in a secure and level position.
- Do not operate without an air filter or in a corrosive environment.

JC10PLUS OVERVIEW & IMPORTANT INSTRUCTIONS

The “JC10” series air compressors are low speed, oil-free direct drives designed to be extremely quiet and provide years of trouble-free service. Super thin reed valves play a major role in the quiet operation but are susceptible to damage from the ingestion of even the smallest piece of foreign material. Therefore, it is vitally important to maintain a structurally sound intake canister along with a clean and solid filter element. Replace entire intake assembly if canister breaks loose from the threaded nipple, and make a habit of checking the pleated intake element on a regular basis to make sure it remains free of holes and tears.

The next generation JC10PLUS is redesigned with a cord wrap and built with longer cylinders that could potentially be flipped to double the service life. However, this series is not rated for 100% or continuous duty, and performs best when given as much rest as run time. If, in order to keep up, you find your compressor consistently running more than five out of every ten minutes then you’ll likely need to shore up some air hose leaks or use a bigger air compressor for the job.

The motor also has automatic thermal overload protection and can restart unexpectedly and repeatedly if an overload occurs. For example, operation above the rated duty cycle due to air hose leaks. Therefore, never leave the air compressor plugged in unattended. If an overload occurs unplug and allow the compressor to cool for several hours before attempting to restart.

SYSTEM CONTROLS

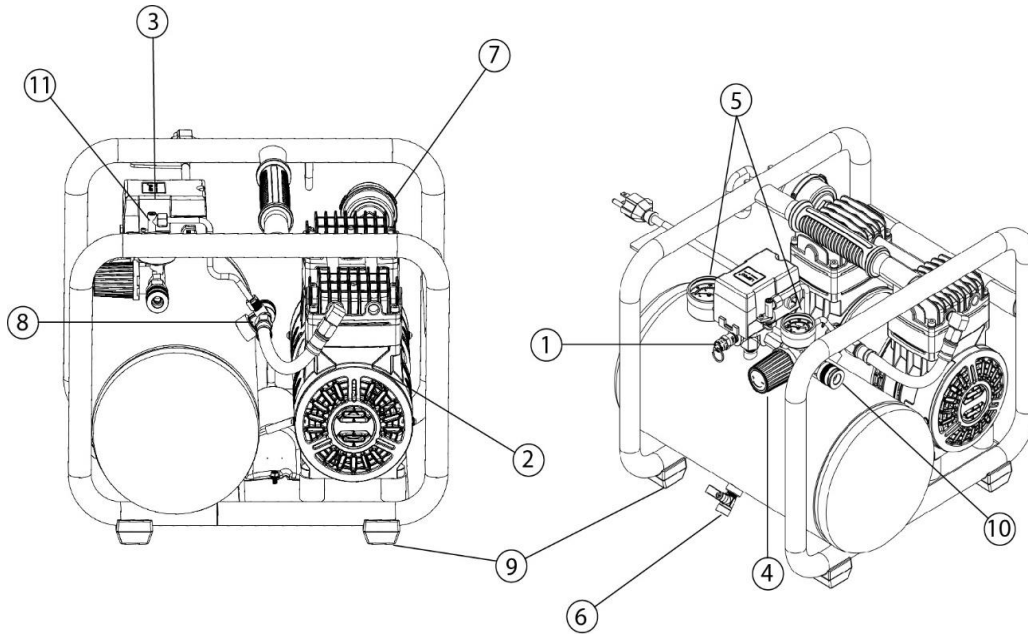

1. SAFETY-RELIEF VALVE Every air compressor is equipped with a safety-relief valve which is designed to discharge tank pressure at a predetermined setting when a systems failure occurs. Check the safety valve daily by pulling on the ring only after the tank pressure has been completely drained. The spring loaded valve should move freely within the safety valve body. An inoperable safety valve could allow an excessive amount of tank pressure to build causing the air tank to violently rupture or explode.



Do not tamper with or attempt to eliminate the safety relief valve.

2. AUTOMATIC INTERNAL OVERLOAD PROTECTION The JC series motor is built with automatic overload protection. When an electrical deficiency occurs or the compressor is operated above its rated duty cycle, the thermal protector will interrupt the power supply and automatically shut down the motor to protect it. When the motor sufficiently cools, it will attempt to restart automatically. If the electrical deficiency that caused the overload to trip is not corrected, the motor will continue to overheat and restart which may lead to a complete motor failure. Therefore, **NEVER LEAVE THE AIR COMPRESSOR PLUGGED IN UNATTENDED.** Always re-evaluate the power source and gauge/length of extension cord being used whenever the automatic internal thermal protector causes the motor to stop running. (Refer to the chart on page 10.)

3. PRESSURE SWITCH Your air compressor operates by the use of a pressure switch. Always make sure the lever is in the "Off" position before plugging in the power cord. By moving the lever to the "On/Auto" position, the compressor will start and stop automatically within the settings of the pressure switch which are typically 95 - 125 PSI. Do not attempt to stop the compressor by unplugging the power cord. To stop, simply move the lever to the "Off" position.

4. REGULATOR – WORKING PRESSURE To adjust the output/line pressure, simply rotate the regulator adjustment knob clockwise to increase working pressure or counterclockwise to decrease. Never exceed the manufacturer's maximum allowable pressure rating of the tool being used or item being inflated. Always relieve pressure from coupler by rotating adjustment knob completely counter-clockwise before removing air hose.

5. PRESSURE GAUGE(S) Typically, most compressors are designed with a gauge to measure tank or storage pressure and another gauge that indicates output or working pressure.

SYSTEM CONTROLS (continued)

6. **DRAIN VALVE(S)** One or more drain valves are installed to allow moisture to be drained on a daily basis from the compressor storage tank(s). Open drains carefully and slowly to prevent scale, rust, or debris from becoming expelled at a high rate of speed.

7. **AIR INTAKE FILTER** An air intake filter is installed to prevent foreign material from entering the compressor pump. Check intake element on a regular basis and either clean or replace as needed. Warm soapy water or low compressed air may be used to clean the element.

8. **CHECK VALVE** Every air compressor is built with a check valve to seal off and maintain tank pressure after the top end pressure setting of pilot valve or pressure switch is reached. The check valve works in conjunction with the pressure switch relief valve to provide a *loadless* start for the compressor system. A quick burst of air escaping from the relief valve after the machine reaches top end indicates the check valve is working properly. If the compressor has a mysterious leak after stopping that cannot be traced elsewhere, the check valve may require servicing/replacing. Always drain tank pressure completely before attempting to remove or service any component.

9. **VIBRATION DAMPENER(S)** The rubber pads installed beneath every portable tank assembly are very important to the proper operation of the air compressor. They provide protection from vibration that left unchecked could cause damage to many system components.

10. **QUICK DISCONNECT** A universal or 3-way quick disconnect is installed on your JC series air compressor. Simply push a 1/4" male plug into coupler to snap hose fitting into coupler. Always relieve pressure from coupler before installing or removing hose. See instructions for regulator (#4 above). Pull back on collar to remove air hose after pressure is relieved.

11. **PRESSURE SWITCH RELIEF VALVE** A normally closed relief valve is installed on the pressure switch to provide the JC10PLUS motor with a "loadless" start. When the air compressor stops automatically, or manually using the on/off lever, the pin for the relief valve is pushed open by a paddle attached to the moveable contacts to dump off or purge head and line pressure. A noticeable burst of air must be released after the air compressor stops in order for the motor to restart at the low pressure setting of 95 PSI. If air leaks continuously from the relief valve after the compressor stops there is a problem with the proper operation of the one way tank check valve. See System Controls (Item #8). If no air is purged after the compressor stops the proper alignment of the relief valve pin and contact paddle has been compromised.

PRE-START CHECKLIST

Read the owner's manual thoroughly. Make sure that you completely understand all of the safety warnings, system controls and instructions provided before attempting to operate this air compressor. Every effort has been made to provide you with the information needed to obtain many years of reliable and trouble-free service out of your new air compressor. It is your responsibility to operate the air compressor properly. To obtain the longest possible service life from your air compressor you must always keep the following instructions in mind.

1. **INSTALL AIR INTAKE FILTER**

Remove metal air cleaner assembly from the bag attached to the compressor with owner's manual. Thread intake filter into open port on pump cylinder head. Reference #7 on the System Controls drawing (page 8) or review schematic and/or picture on box for proper location to install air cleaner.

2. **OPERATE IN A CLEAN, DRY AND WELL VENTILATED AREA**

Allow at least 18" behind the belt guard for proper cooling of pump from flywheel blast. Do not operate in the rain or in areas of standing water. Never operate in an area where other gases, fumes or vapors are present which may become explosive when compressed. Do not operate compressor in an enclosed area or with any of the ventilation openings covered.

PRE-START CHECKLIST (continued)

3. INSPECT/CLEAN/CHANGE INTAKE ELEMENTS ON A REGULAR BASIS

The ingestion of dirt into the pump is the primary cause of premature wear. Pay special attention to the intake filter. Check intake element daily.

4. USE LONGER PROPERLY SIZED AIR HOSE RATHER THAN EXTENSION CORDS

If an extension cord must be used, please refer to the chart on the following page for the proper gauge and maximum length that can be used. The use of inadequately sized air hose will also lead to frictional pressure drops that could affect the proper performance of your air tools.

ELECTRIC EXTENSION CORD TABLE

Minimum Wire Size		
Extension Cord Length	Motor 1/2 and 3/4 HP	Motor 1, 1-1/2, and 2 HP
Up to 25 ft.	14 Ga.	12 Ga.
25 – 50 ft.	12 Ga.	10 Ga.
50 – 100 ft.	10 Ga.	8 Ga.

Power Cord

A/B Plug Type
60 Hz, 120 V

This product is for use on a 120-volt circuit and should be grounded. A cord with a grounding plug as illustrated must be used. No adapter should be used with this product.

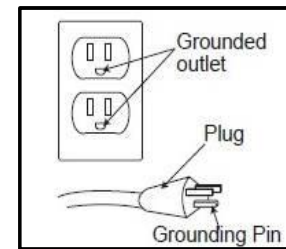

5. DO NOT USE A GENERATOR AS THE POWER SOURCE

Air compressors use inductive motors that require 3-5 times the full-load amp draw to properly start. Most generators will not provide the wattage needed to properly start this type of electric motor.

6. CHECK TENSION OF BOLTS, BELTS, AND HARDWARE ON A REGULAR BASIS

Operation of any equipment with loose bolts and/or fittings will lead to excessive vibration and the premature failure of the compressor system control components.

7. MAINTAIN RUBBER VIBRATION PADS

Excessive vibration is a major cause of premature compressor failure. Always maintain the rubber vibration pads located beneath tank assembly. Operation without them will void your warranty.

8. DRAIN MOISTURE FROM AIR TANK DAILY

Water is a natural byproduct of compressed air. Drain air tank(s) after each use to combat internal tank corrosion. Keep drain valve(s) closed if storing compressor for any length of time.

SPECIFICATIONS

	JC10PLUS		JC10PLUS
Horsepower	1.0	Tank Capacity	2.5 Gallon
Voltage	120 V	Pump-Up Time (0-125 PSI)	:55 seconds
Hertz	60 hZ	Recovery Time (95-125 PSI)	:14 seconds
Motor RPM	1700	CFM Displacement	5.3
Stage(s)	Single	CFM Free Air @ 90 PSI	2.4
Amperage	7.5	Dimensions (LxWxH – in.)	16.34”x16.34”x13.78”
Thermal Protection	Automatic	Weight (lb.)	45
Factory Settings	95 – 125 PSI	Noise Level (dBA)	60

OPERATION

WARNING – Your safety and the wellbeing of others during the operation of every compressor is our main concern. Do not operate or permit anyone else to operate your air compressor until the information contained in this manual is read and completely understood. Please contact your distributor or our customer service department if you have any questions on the proper use of your air compressor.

WET CONDITIONS: Do not operate your compressor in damp or wet conditions, or after it has been exposed to rain/sleet/ice/snow or moisture of any kind. Failure to follow this warning could lead to electric shock and/or rust and ice forming on critical components, making the compressor dangerous to operate. Always operate and/or store compressor in a clean, dry location with good ventilation.

1. Wear eye protection.
2. Inspect machine to make sure bolts are tight, vibration pads are secure, power cord is solid, compression fittings are tight, and the air intake filter is clean, solid and tightly installed.
3. Position compressor in a clean, dry location with plenty of ventilation and away from volatile vapors and gases. Never start machine with any of the ventilation openings covered.
4. Slowly open tank drain to remove any condensate that has accumulated. Keep drain open for 20 – 30 seconds after starting compressor to “warm-up” motor and pump.
5. Make sure pressure switch lever is in the “Off” position before plugging machine into a properly grounded outlet. Never unplug machine until moving lever to “Off” position.
6. Move lever to “On” position and close tank drain to build tank pressure after allowing machine to warm up for a few seconds with the drain open.
7. Attach air hose only after rotating regulator adjustment knob counter-clockwise to relieve any pressure that has built up.
8. Rotate regulator adjustment knob clockwise until desired working pressure is reached.
9. When task is complete, rotate regulator adjustment knob counter-clockwise to relieve pressure prior to removing air hose. Open drain slowly to drain moisture and prepare for next start. Rotate pressure switch lever to “Off” position before unplugging.
10. Store compressor in a warm/dry location and perform maintenance as indicated in manual.

NOTE: DO NOT SUBJECT COMPRESSOR TO CONTINUOUS USE. The JC series air compressors are rated for 70% duty-cycle. If operated for more than forty minutes per hour, the motor will overheat and cause the internal overload to shut down the compressor. The overload will also allow the motor to automatically restart after the motor has sufficiently cooled, which can be unexpected. Therefore, **NEVER** leave the air compressor plugged in unattended.

FREEZING TEMPERATURES:

Proper fluid maintenance and warm up procedures are mandatory before attempting to start or operate an air compressor in freezing temperatures. Water, a natural byproduct of compressed air, could turn into ice and potentially block air flow into, through, and/or out of the pump, air tank(s), and air line(s). Drain air tanks/lines after every use and leave drain valves open when not in use.

If all, or part, of the compressor may be frozen, you must completely thaw the compressor before attempting to start. Gradually increase the temperature above freezing and then drain moisture from the air tanks, intercoolers, and water traps.

Cold Weather Best Practices:

- Do not attempt to start a frozen compressor. Thaw completely first.
- Store your air compressor in a clean, dry area that stays consistently above freezing temperatures.
- Change the oil in the pump and engine to winter grade (check owner’s manual).
- Prior to starting, open the tank drain(s) and allow the compressor to run for 45-60 seconds with the tank drain(s) open before closing to build tank pressure.
- Using a lubricator with de-icing fluid may also be needed to keep your air lines from freezing up/blocked by ice.

OPERATION (continued)

HIGH-ALTITUDE OPERATION:

Due to a decrease in atmospheric pressure air compressor pumps produce less CFM at higher elevations. As a rule of thumb the output will decrease approximately three percent per 1000 feet of elevation. Also, because air at higher elevations is less dense and does not cool as well, electric motors cannot be subjected to the full nameplate service factor amp rating and may need to be upgraded to avoid repeated overheating.

Direct drive or hand-carry compressors built with cold-start valves may need to be modified when operated in higher elevations. Contact our factory Customer Service Department if your normally reliable air compressor fails to operate correctly at higher elevations.

MAINTENANCE

Your new air compressor represents the finest engineering and construction available. Even the best machinery requires periodic maintenance. Please stick to the maintenance schedule and consider the suggestions that follow to keep your compressor in peak condition.

NOTE: Always unplug or shut down your compressor and drain the air tanks completely before attempting any type of maintenance. Wait for compressor to cool before servicing.

MAINTENANCE HINTS:

- 1) Use a soap/water solution to check for air leaks.
- 2) Never clean filters with a flammable solvent.
- 3) Retorque head bolts only after pump has cooled.
- 4) Never weld on air tank(s).
- 5) Use heat to loosen Loctite seal on drains and other fittings before attempting to remove.

MAINTENANCE SCHEDULE

Recommendation	Daily	Weekly	Monthly	Quarterly	Annually
Drain Moisture from Tank(s)	X				
Inspect Air Filter(s)	X				
Check for Unusual Noise or Vibration	X				
Check for Air Leaks	X				
Clean Exterior of Air Compressor		X			
Check Condition of Vibration Pads		X			
Tighten/Retorque Bolts		X			
Check Operation of Safety Valve		X			
Clean/Change Air Filter			X		
Perform Pump Up Time Test			X		
Check Operation of System Controls				X	
Check Air Tanks for Dents/Leaks				X	
Tank Inspection by Certified Inspector					X

TROUBLESHOOTING

WARNING - Make sure you completely understand all of the safety warnings and operation of each system control component before attempting any maintenance or repair. Always drain the tank pressure completely, make sure the power cord is unplugged, and unit has time to cool before performing any maintenance or service operations.

PROBLEM	CAUSE	SOLUTION
Motor makes no noise when power is applied	Tank pressure is full	Drain below 95 PSI to restart
	Automatic overload has stopped compressor due to overheating	Unplug, drain tank pressure and allow to cool before restarting. Evaluate power supply and extension cord used
Motor hums but does not start/run	Motor windings are fried	Take in for service. Evaluate power supply and duty cycle
	Capacitor has failed	Replace and retest
Motor runs but pump will not reach top pressure setting of 125 PSI	Excessive external leaks at tank drain, regulator, hoses, etc.	Use soap/water solution to identify and correct leaks
	Broken valve, blown gasket or other internal issue	Inspect valve plates or take in for service
Unit does not maintain tank pressure after stopping at 125 PSI and leaks continuously from pressure switch relief valve	Disc and spring inside check valve are not sealing	Drain tank pressure completely. Unthread check valve inspection cap and clean debris from disc
Unit runs great for close to an hour before suddenly stopping	Excessive external leaks on unit or air hose/fittings	Use soap/water solution to identify and correct leaks
	Unit is undersized or is being worked above 70% duty cycle	Use larger air compressor for this application
Pump builds tank pressure above 125 PSI, causing safety valve to blow/pop off	Pressure switch contacts are stuck together	Unplug, inspect contacts and replace pressure switch if necessary
	Pressure switch port is plugged with ice or debris	Bring inside to unthaw drain water from tank and restart or take in for service
Compressor is louder than normal and slow to build pressure	Broken valve, bearing failure or debris inside pump	Inspect valve plates and piston tops or take in for service