



MASTER MOBILE PROBLAST ENGLISH

1. CONDITIONS FOR USE

This micro abrasive blaster may only be operated:

- Indoors;
- Below 1981 m (6500 ft) above sea level altitude;
- Ambient air temperature between 40°-105°F (5-40°C);
- Maximum relative humidity of 80% at 31°C (88°F);
- Power supply current fluctuations does not exceed 10% of nominal value;
- Under level 2 contamination conditions;
- Supply cool, dry air only, at a maximum pressure of 10.3 Bar (150 PSI).

2. SAFETY



WARNING: Read all safety warnings, instructions, illustrations and specifications provided with this power tool. Failure to follow all instructions listed below may result in electric shock, fire and/or serious injury.

Save all warnings and instructions for future reference.

The term "power tool" in the warnings refers to your mains-operated (corded) power tool or BATTERY-operated (cordless) power tool.

1. Work area safety:

- Keep work area clean and well lit.** Cluttered or dark areas invite accidents.
- Do not operate power tools in explosive atmospheres, such as in the presence of flammable liquids, gases or dust.** Power tools create sparks which may ignite the dust or fumes.
- Keep children and bystanders away while operating this power tool.** Distractions can cause you to lose control.

2. Electrical Safety:

- Power tool plugs must match the outlet. Never modify the plug in any way. Do not use any adapter plugs with earthed (grounded) power tools.** Unmodified plugs and matching outlets will reduce risk of electric shock.
- Avoid body contact with earthed or grounded surfaces, such as pipes, radiators, ranges and refrigerators.** There is an increased risk of electric shock if your body is earthed or grounded.
- Do not expose power tools to rain or wet conditions.** Water entering a power tool will increase the risk of electric shock.
- Do not abuse the cord. Never use the cord for carrying, pulling or unplugging the power tool. Keep cord away from heat, oil, sharp edges or moving parts.** Damaged or entangled cords increase the risk of electric shock.

ENGLISH

- e. **When operating a power tool outdoors, use an extension cord suitable for outdoor use.** Use of a cord suitable for outdoor use reduces the risk of electric shock.
- f. **If operating a power tool in a damp location is unavoidable, use a RESIDUAL CURRENT DEVICE (RCD) protected supply.** Use of an RCD reduces the risk of electric shock.

3. Personal Safety

- a. **Stay alert, watch what you are doing and use common sense when operating a power tool. Do not use a power tool while you are tired or under the influence of drugs, alcohol or medication.** A moment of inattention while operating power tools may result in serious personal injury.
- b. **Use personal protective equipment. Always wear eye protection.** Protective equipment such as dust mask, non-skid safety shoes, hard hat, or hearing protection used for appropriate conditions will reduce personal injuries.
- c. **Prevent unintentional starting. Ensure the switch is in the off-position before connecting to power source and/or BATTERY pack, picking up or carrying the tool.** Carrying power tools with your finger on the switch or energizing power tools that have the switch on invites accidents.
- d. **Remove any adjusting key or wrench before turning the power tool on.** A wrench or a key left attached to a rotating part of the power tool may result in personal injury.
- e. **Do not overreach. Keep proper footing and balance at all times.** This enables better control of the power tool in unexpected situations.
- f. **Dress properly. Do not wear loose clothing or jewelry. Keep your hair, clothing and gloves away from moving parts.** Loose clothes, jewelry or long hair can be caught in moving parts.
- g. **If devices are provided for the connection of dust extraction and collection facilities, ensure these are connected and properly used.** Use of dust collection can reduce dust-related hazards.
- h. **Do not let familiarity gained from frequent use of this tools allow you to become complacent and ignore tool safety principles.** A careless action can cause severe injury within a fraction of a second.

4. Power tool use and care:

- a. **Do not force the power tool. Use the correct power tool for your application.** The correct power tool will do the job better and safer at the rate for which it was designed.
- b. **Do not use the power tool if the switch does not turn it on and off.** Any power tool that cannot be controlled with the switch is dangerous and must be repaired.
- c. **Disconnect the plug from the power source and/or remove the BATTERY pack, if detachable, from the power tool before making any adjustments, changing accessories, or storing power tools.** Such preventive safety measures reduce the risk of starting the power tool accidentally.

ENGLISH

- d. **Store idle power tools out of the reach of children and do not allow persons unfamiliar with the power tool or these instructions to operate the power tool.** Power tools are dangerous in the hands of untrained users.
 - e. **Use the power tool, accessories and tool bits etc. in accordance with these instructions, taking into account the working conditions and the work to be performed.** Use of the power tool for operations different from those intended could result in a hazardous situation.
 - f. **Keep handles and grasping surfaces dry, clean and free from oil and grease.** Slippery handles and grasping surfaces do not allow for safe handling and control of the tool in unexpected situations.
- 5. Service**
- a. **Have your power tool serviced by a qualified repair person using only identical replacement parts.** This will ensure that the safety of the power tool is maintained.

3. SPECIAL ATTENTION TO THIS PRODUCT

- Unplug equipment from the wall before changing out the LED light. Do not squeeze or bend the light tube. Always wear gloves or use a towel to protect your hands from glass splinters.
- Always disconnect the unit from the compressed air and power sources before beginning any maintenance.
- Any abrasive material on the o-ring may lead to leakage and early wear of the o-ring. After filling, clean the thread and o-ring before applying the lid.
- Solvents will create cracks in the jar and weaken the jar (danger of explosion!). Clean the lid and tank only with a dry cloth. Do not write or adhere anything to the jar or lid.
- Check for damages on the lids and tanks regularly and replace them if there is any doubt of the structural integrity.
- Before operation, check to make certain the lid is secured properly. Using the product without the lid secured will create a serious explosive hazard.
- Never operate the blasting units without suitable dust extraction and appropriate protective gear. The type of dust extraction should be based on the type dust generated. Ask the proper authorities.
- Never direct the blasting material towards eyes or unprotected areas of skin. Improper use can result in risk of eye or skin injuries.
- Never work with the glass door open.
- Do not depress the foot switch when only the compressed air supply hose is connected. The loose hose could wrap around itself and cause serious injury.
- Maintain equipment and accessories. Check for breakage of parts and any other condition that may affect the equipment's operation.

ENGLISH

- The triangular light symbol labelled on the light indicates that the user should not look directly into the light and that doing so may cause eye damage.



- Please note that correct use requires reference to this manual and that the following label indicates that the user should reference this manual prior to operation.



4. LIABILITY EXCLUSION

Vaniman Manufacturing shall be absolved from all claims for damages and warranty if:

- The product is used for any purpose other than it was designed for.
- The product is altered in any way other than those described in the operating instructions.
- The product is repaired by anybody other than an authorized facility or if any parts other than Vaniman OEM parts are used.
- The product continues to be employed, despite obvious safety faults.

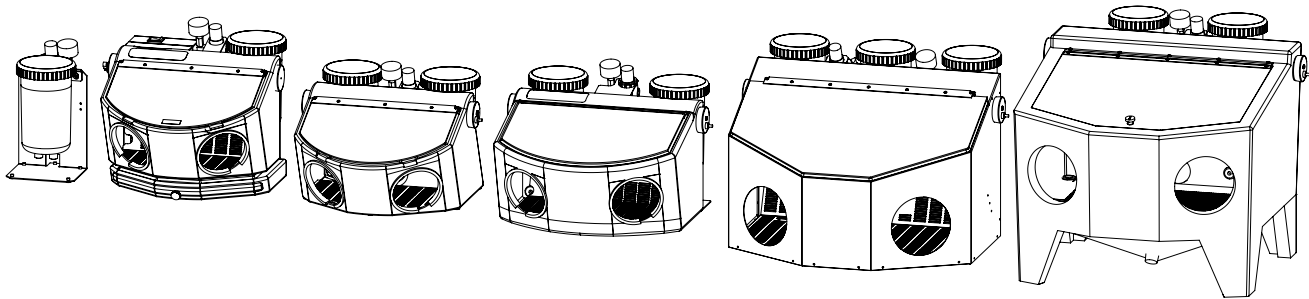

PACKING LIST

- 1 - Micro-Abrasive Blaster
- 1 - Instructions
- 1 - DC Power Supply (if applicable)
- 1 - Additional Air Supply Connection

INSTALLATION & OPERATION

1. Remove the unit and all packaging material from the box. Check against the packing list.
2. For units with lights: Plug the DC Power Supply into the jack on the unit's light and plug the other end into a standard outlet.
3. Unscrew lid(s) on abrasive storage tank(s) and fill to the line marked on the tank. Do not overfill as clogging may result.
4. Inspect lid and tank for any cracks or areas that might create leaks. Ensure the threads on the tank and lid are clean of abrasive before screwing the lid securely back into place. Do not over-tighten.
5. Use the plumbing diagrams at the end of these instructions to locate the fitting on the back of the unit to connect your air supply line. Most units come equipped with a barbed fitting for a 1/4" (6mm) ID (inside diameter) hose while the IO/Master units come equipped with a quick disconnect fitting for a 1/4" (6mm) OD (outside diameter) air line. All Vaniman units are shipped with both fittings included to meet the customer's needs. For more help on connecting your unit to an air supply visit:

www.vaniman.com/air-supply-connections-blasters/

6. Regulate air pressure by turning the air regulator knob, pulling up on the knob to unlock and pressing back down to lock. The pressure reading will be indicated on the pressure gauge and should NOT be adjusted above 100 psi (7 BARS).
7. Never depressurize the system by disconnecting the air supply line while under pressure; abrasive will be forced into the foot valve and regulator, causing damage. Before disconnecting the air supply line, turn the regulator down (counterclockwise) until the pressure gauge reads zero.

ENGLISH

8. Press the foot pedal to start the flow of air and blasting media. Release the foot pedal to stop the flow.
9. It is recommended that a dust collector is attached to the unit to remove excess media and improve visibility during blasting.

SandVac	120V	PN: 10211
StoneVac II	120V	PN: 10201

SandVac	220V	PN: 10212
StoneVac II	220V	PN: 10209

MAINTENANCE

Vaniman blasters are designed to be low maintenance. However, as the materials used in a microblaster are abrasive by design, components do wear out. A few minor areas should be maintained regularly for a long product life.

Handpieces Hoses:

Check handpiece hoses for wear regularly. When hose feels thin or holes develop, the tubing should be replaced.

On the rear of IO/Master units, there is a pinch valve that controls the flow of media by squeezing and releasing the handpiece tube. This will be the point of highest wear on the tubing and therefore the hose should be moved periodically in order to wear a new section of hose. If a hole develops, replace the tubing.

Handpiece Tip Installation:

It is imperative that the handpiece tip and sealing o-ring be installed correctly and securely to avoid damage or leaks. Install in the manner shown in Figure 1 and ensure the tip and o-ring sit evenly in the assembly.

Tanks:

When installing the lids on the tanks, be sure the lid is rid of any blasting material or debris. If the tank or lid begins to wear, replace immediately. Do not over-tighten the lid on the unit. The fittings on the bottom of the tank are designed for easy maintenance of the hoses. To remove a handpiece tubing from quick disconnect fitting, push toward the tank on the plastic ring while pulling the tubing out. Do not remove the hose fittings while tank is full of media and upright; turn the tank upside down or empty before removing hoses. To replace, be sure the fitting and hose are free of debris or abrasives and push the hose firmly into the fitting. Be sure the tube reaches beyond the black o-ring that is just above the quick disconnect fitting in the tank. Improper installation will result in leakage and damage to the tanks.

INSTRUCTIONS

1. Remove the tubing from the bottom fitting of the sand tank. See Figure 3 for instructions on quick fittings.
2. Remove the handpiece assembly ⑦ (Fig. 2) from inside the cabinet by pulling the tubing through the rubber grommet.
3. Unscrew the nozzle cap ⑥ to remove the tip ⑤ and O-ring ④. Using pliers, grasp the handpiece insert ③ and pull the tubing through the handle ② with a twisting motion. Avoid damaging the insert. Twist and pull to separate the insert from the tubing.

NOTE: Some units may have a steel barbed nozzle inside the tubing. This must be removed and discarded, as it cannot be used with the new long lasting polyurethane tubing. If needed, moisten or warm the tubing in hot water to make removal easier. This may help when reinstalling tubing onto the barb at the bottom of the sand tank.

4. Using the new tubing, feed it through the handle with a twisting motion. Once the tubing extends several inches past the front of the handle, press the handpiece insert ③ fully into the end of the tubing until the tubing is flush with the front of the insert. Moistening the tubing may help with installation.
5. Pull the tubing back into the handle until the insert collar sits firmly against the end of the handle. Pull the tubing through the rubber grommet, blow out tank bottom fitting and re-attach it to the sand tank assembly by pushing it into the quick-release fitting. Visually make sure the tube travels past the black seal looking through the transparent raised area (Fig. 1). Re-assemble the O-ring, tip and nozzle cap to the handle.

OPTIONAL VIDEO REFERENCES

- Tank Replacement: <https://www.vaniman.com/tank>
- Handpiece Replacement: <https://www.vaniman.com/handpiece>

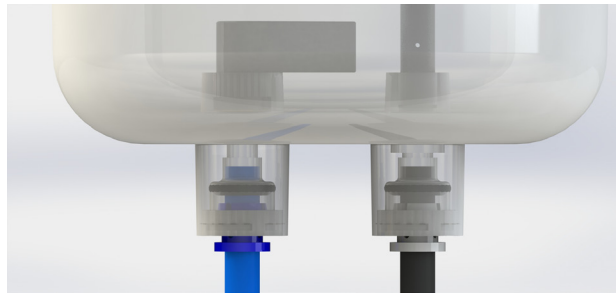

Figure 1

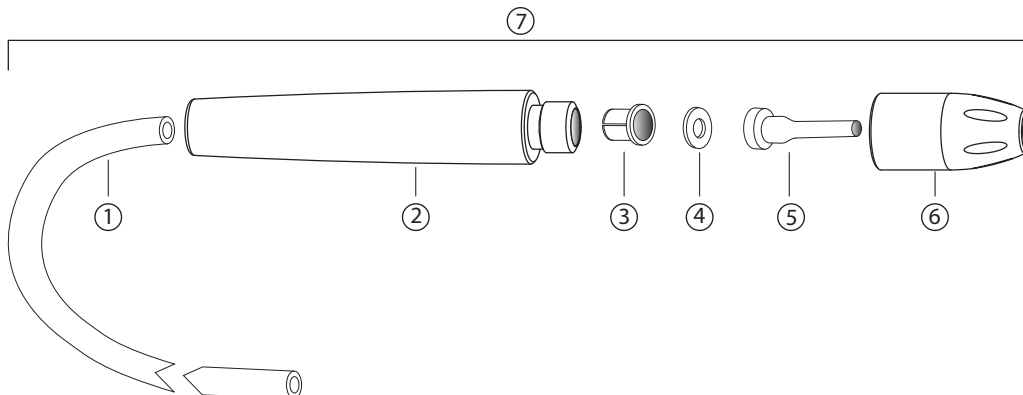

Figure 2

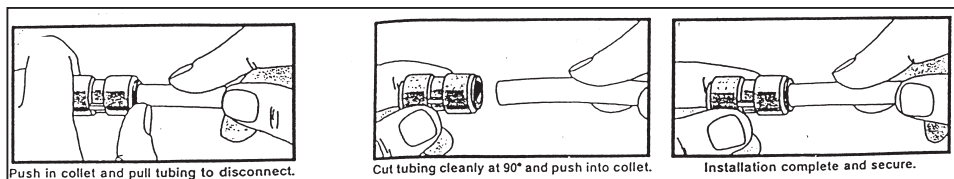

Figure 3

HANDPIECE PARTS

Number	Description	Part Number	Corresponding unit
1	Anti-Static Handpiece Tubing	97928 (2ft.) 97929 (3ft.) 97930 (4ft.) 97999 (6ft.) 2192 (by the foot)	SandStorm Edge, Professional, 2, Expert, & Problast 2 SandStorm XL & Problast SandStorm Prestige & Problast 3 Problast Titan, Sandstorm Mobile & Mobile Problast -
2	Handle	2191	All Units
3	Handpiece Insert	2187	All Units
4	O-Ring	97909 (5-pack)	All Units
5	Tip (o-ring included)	See Below	All Units
6	Nozzle Cap	2177	All Units
7	2ft. Handpiece Assembly* 3ft. Handpiece Assembly* 4ft. Handpiece Assembly* 6ft. Handpiece Assembly*	97947 97949 97959 98109	SandStorm Edge, Professional, 2, Expert, & Problast 2 SandStorm XL & Problast SandStorm Prestige & Problast 3 Problast Titan, SandStorm Mobile & Mobile Problast

*Does not include o-ring or tip

BLASTER TIPS

Tip Type	Part No.	Color	Nozzle Size	Recommended Vaniman Media	Recommended Tank Assembly	
					Part Number	Description
Crystal Tip (2 per pack)	97902	Blue	Medium 0.032" (0.8mm)	25µm Al2O3	97956	25µm
				50µm Al2O3	97957	50-100µm
	50µm Glass Bead					
	100µm Al2O3					
	50µm Glass Bead					
	97904	Red	Extra Large 0.065" (1.6mm)	100µm Al2O3	97958	110-250µm
250µm						
Tungsten Carbide Tip (1 per pack)	97905	Yellow	Small 0.026" (0.65mm)	25µm Al2O3	97956	25µm
				50µm Al2O3	97957	50-100µm
	50µm Glass Bead					
	100µm Al2O3					
	97907	Violet	Large 0.059" (1.5mm)	80/100 VanAcrylic	97958	110-250µm
				50µm Glass Bead		
100µm Al2O3						
				250µm Al2O3		

BLASTER MEDIA [HTTPS://WWW.VANIMAN.COM/MEDIA-SELECTOR/](https://www.vaniman.com/media-selector/)

Material	Size	Part Number			Applications
		55lbs.	15lbs.	One Tank	
Aluminum Oxide	25µm	98201	97921	97935	Fine surfacing of metal and other hard materials.
	50µm	97927	97922	97936	Deburring and deflashing of metals and other hard materials.
	100µm	98202	97923	97937	Aggressive removal of materials, semi-rough finished surface.
	250µm	98203	97924	97938	Bulk removal or surface cleaning of tough materials. Rough surface preparation.
Glass Bead	50µm	98204 (50 lbs)	97925	97939	Smoothing/polishing. Cleans and polishes without removing material.
Sodium Bicarbonate	50-100µm	98206 (50 lbs.)	97934	98200	Aggressive removal of materials, water soluble and does not embed into the material.
Walnut Shell	200 Grit	-	97933	-	Organic, used for cleaning purposes.
	40/100 Grit	98207 (50 lbs.)	97932	-	
	20/40 Grit	97931 (50 lbs.)	-	-	
VanAcrylic Media	80/100 Grit	98210 (30 lbs.)	98209 (5 lbs.)	98208	Conformal coating removal, delicate paint removal.

* The recommended tank for 80/100 VanAcrylic media is 50-100 micron, paired with a large violet tip.

* For 60/80 VanAcrylic media and 40/100 or 20/40 Walnut Shell, use only in siphon-style sandblasters. Inquire with Vaniman for detailed information.

SANDSTORM MOBILE IO

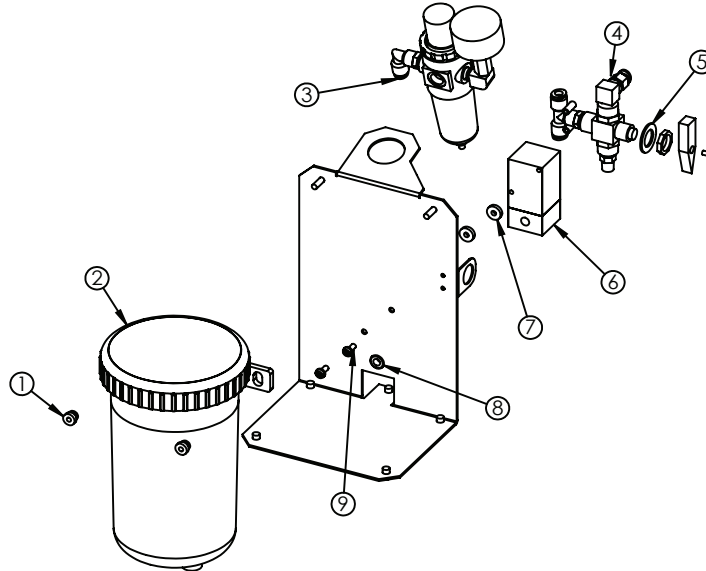

1	2266	Thumb Nut	Tuerca Manual	Ecrou à oreille	Halterungs- mutter	Dado ad alette
2	97956 97957 97958	Sand Jar Assem- bly 25µm Sand Jar Assem- bly 50-100µm Sand Jar Assem- bly 110-250µm	Ensamblaje de Tubo de Arena de 25 micrones Ensamblaje de Tubo de Arena de 50-100 mi- cronos Ensamblaje de Tubo de Arena de 110-250 micrones	Ensemble récipi- ent de sable 25 micron Ensemble récipi- ent de sable 50- 100 micron Ensemble récipi- ent de sable 110- 250 micron	Sandbehälter 25 micron Sandbehälter 50-100 micron Sandbehäl- ter 110-250 micron	Gruppo del ser- batoio sabbia 25 micron Gruppo del serba- toio sabbia 50-100 micron Gruppo del serba- toio sabbia 110-250 micron
3	2660	Regulator	Ensamblado de Regula- dor de Filtro	Ensemble régula- teur filtre	Filter/Regler Baugruppe	Gruppo regolatore del filtro
4	2283	Vent Valve	Válvula ensamblada de ventilación	Ensemble de soupape de venti- lateur	Baugruppe Entlüftungs- ventil	Gruppo Valvola di Sfogo
5	2036	Washer	Arandela	Rondelle	Unterlegs- cheibe	Guarnizione
6	2234	Pinch Valve	Válvula	Vannes à pince- ment	Quetschventil	Valvola a Manicotto
7	3073	Spacer	Espaciador	Entretoise	Distanzstück	Distanziale
8	2819	Grommet	Pasamuros	Oeillet	Gummitülle	Passacavo
9	1517	Screw	Tornillo	Vis	Schraube	Vite
-	2650	Master Foot Pedal	Pedal Maestro	Pédale de pied Master	Master Fußpedal	Pedale Master

PLUMBING

SANDSTORM MOBILE

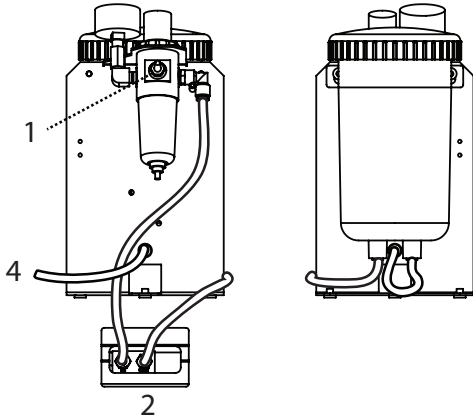

SANDSTORM MOBILE IO

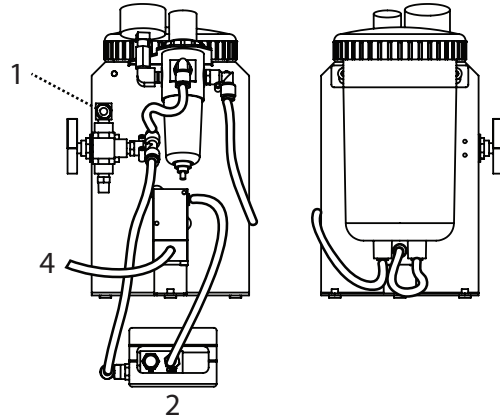

SANDSTORM PROFESSIONAL

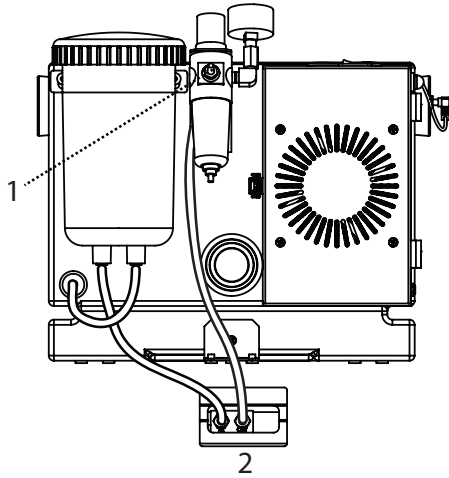

SANDSTORM EDGE

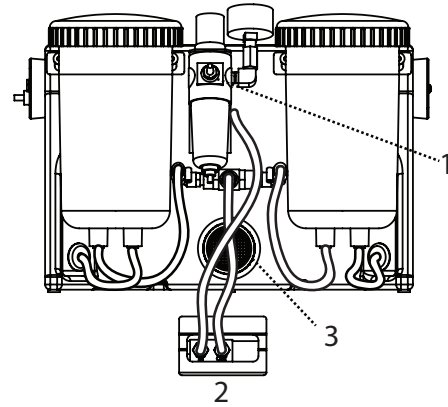

SANDSTORM 2

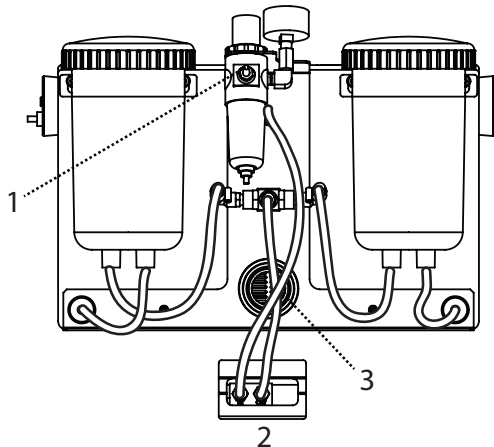

1	Air in	De aire	Air	Luft in	Ingresso Aria
2	Foot Pedal	Pedal de pie	Pédale	Fußpedal	Pedale
3	Dust Collector Port	Puerto del colector de polvo	Collecteur de poussière	Staubsammler Port	Porta Raccogli Polvere
4	Handpiece Tube	Tubo aplicador	Tube du manche	Handstück Schlauch	Tubo Impugnatura