

6

5

4

3

2

1

REVISIONS				
ZONE	REV.	DESCRIPTION	DATE	APPROVED
	REL-J	Changed width of filter cover.	7/30/10	

D

C

B

A

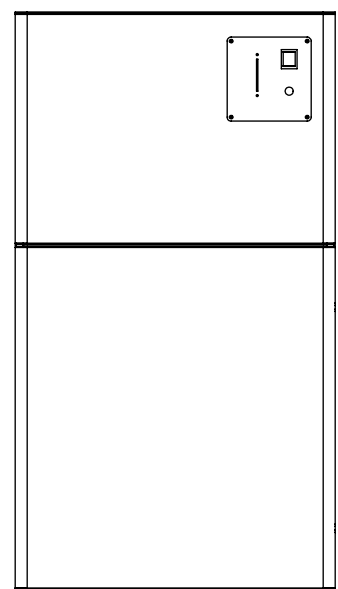
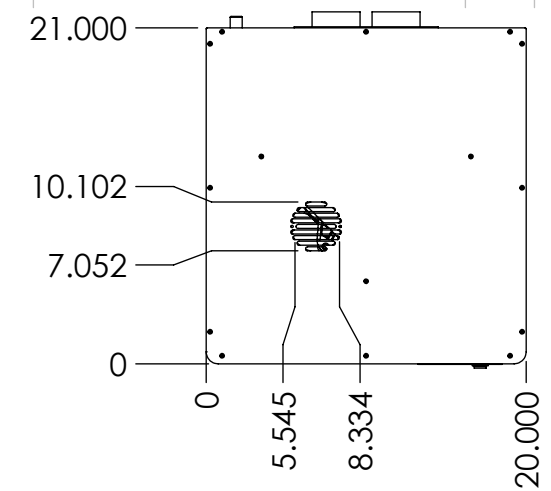
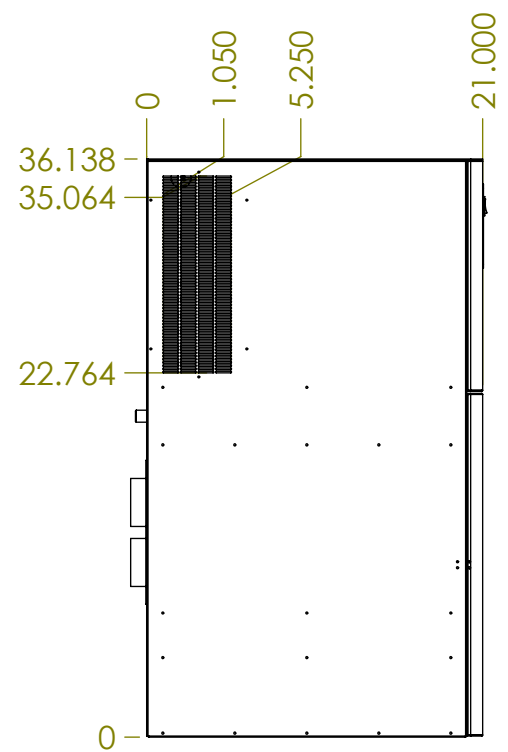
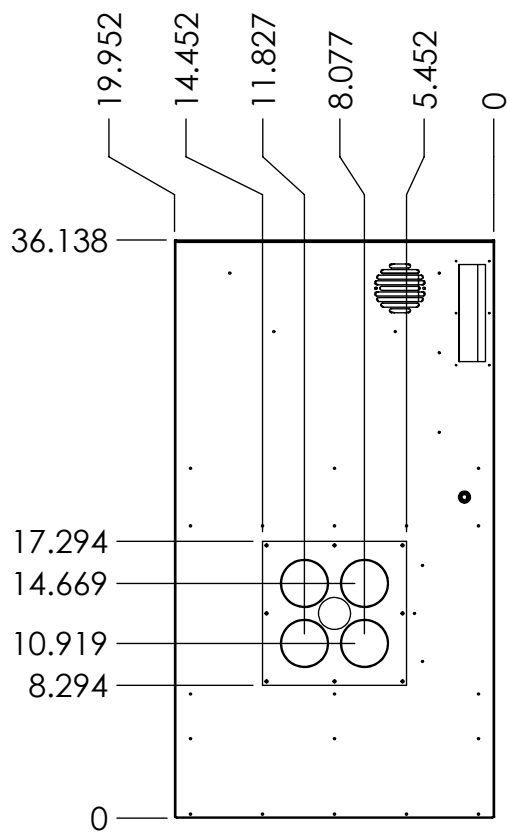

PROPRIETARY AND CONFIDENTIAL

THE INFORMATION CONTAINED IN THIS DRAWING IS THE SOLE PROPERTY OF VANIMAN MANUFACTURING COMPANY. ANY REPRODUCTION IN PART OR AS A WHOLE WITHOUT THE WRITTEN PERMISSION OF VANIMAN MANUFACTURING COMPANY IS PROHIBITED.

		DIMENSIONS ARE IN INCHES TOLERANCES: FRACTIONAL $\pm 1/32$ ANGULAR: $\pm 1^\circ$ ONE PLACE DECIMAL $\pm .05$ TWO PLACE DECIMAL $\pm .03$ THREE PLACE DECIMAL $\pm .005$		NAME	DATE
		MATERIAL		DRAWN	jvaniman 7/20/2017
		FINISH		CHECKED	
NEXT ASSY		USED ON		ENG APPR.	
APPLICATION		DO NOT SCALE DRAWING		MFG APPR.	
				Q.A.	
				DESCRIPTION:	
				FILE DATE:	7/20/2017

VANIMAN MANUFACTURING CO.

VANIMAN
MANUFACTURING CO.
A dba of VMC International, LLC

140 N. Brandon Road - Fallbrook, CA 92028
phone: (760) 723-1498 - fax: (760) 723-6990
e-mail: technical@vaniman.com

SIZE **A** DWG. NAME V6 AR Vent locations REV. REL-J

SCALE: 1:24 PART NO. 3209 SHEET 1 OF 2

6

5

4

3

2

1

ZONE		REV.	DESCRIPTION	DATE	APPROVED

D

C

B

A

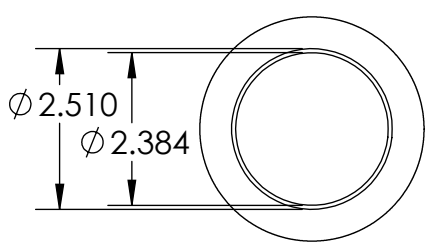
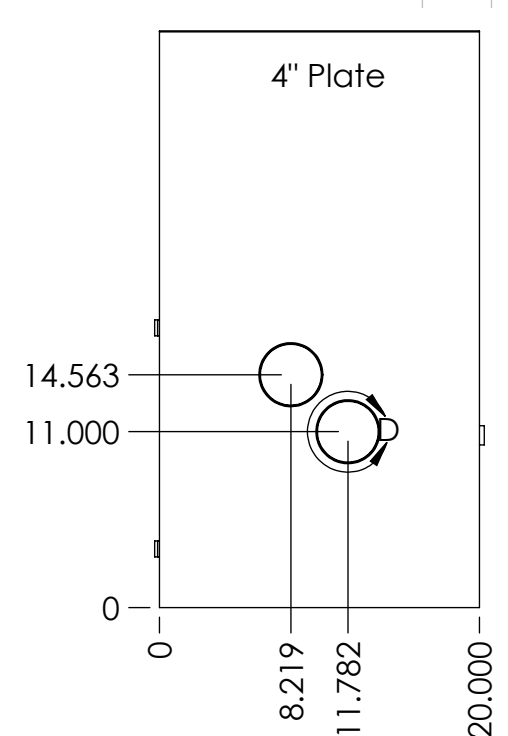
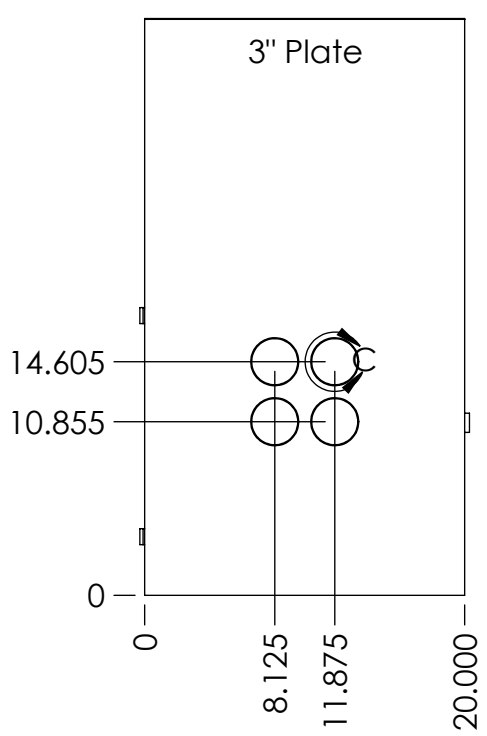
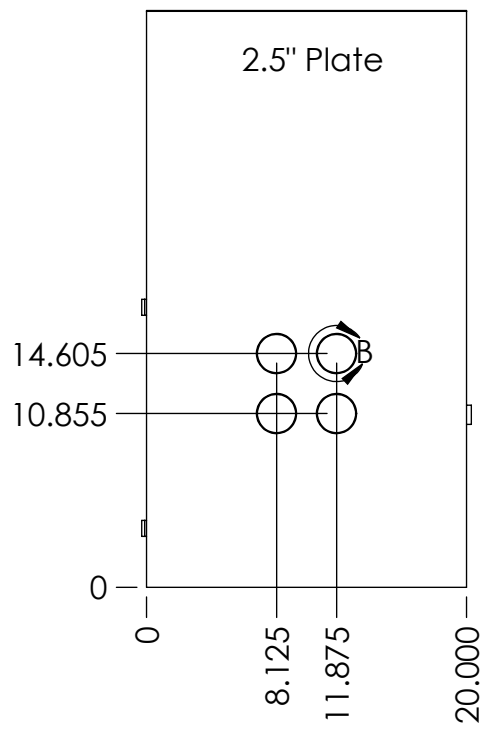

DETAIL B
SCALE 1 : 3

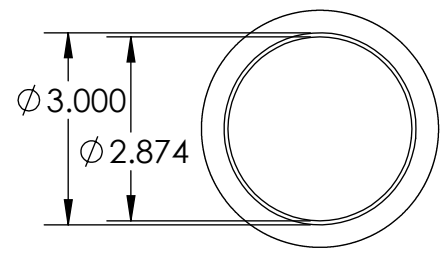

DETAIL C
SCALE 1 : 3

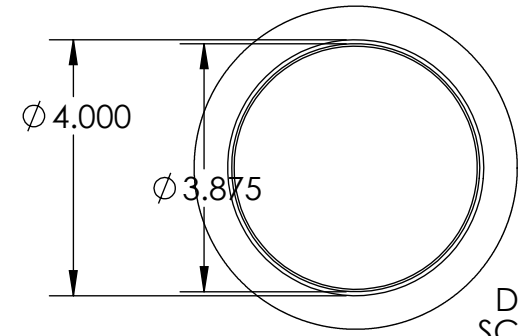

DETAIL D
SCALE 1 : 3

PROPRIETARY AND CONFIDENTIAL
 THE INFORMATION CONTAINED IN THIS DRAWING IS THE SOLE PROPERTY OF VANIMAN MANUFACTURING COMPANY. ANY REPRODUCTION IN PART OR AS A WHOLE WITHOUT THE WRITTEN PERMISSION OF VANIMAN MANUFACTURING COMPANY IS PROHIBITED.

		DIMENSIONS ARE IN INCHES TOLERANCES: FRACTIONAL ±1/32 ANGULAR: ±1° ONE PLACE DECIMAL ±.05 TWO PLACE DECIMAL ±.03 THREE PLACE DECIMAL ±.005		NAME	DATE
		MATERIAL		DRAWN	7/20/2017
		FINISH		CHECKED	
NEXT ASSY		USED ON		ENG APPR.	
APPLICATION		DO NOT SCALE DRAWING		MFG APPR.	
				Q.A.	
				DESCRIPTION:	
				FILE DATE:	7/20/2017

VANIMAN MANUFACTURING CO.
VANIMAN
 MANUFACTURING CO.
 A dba of VMC International, LLC
 140 N. Brandon Road - Fallbrook, CA 92028
 phone: (760) 723-1498 - fax: (760)723-6990
 e-mail:technical@vaniman.com

SIZE	DWG. NAME	REV.
A	V6 AR Vent locations	

SCALE:1:16 PART NO. SHEET 2 OF 2